

AQUAPURE

Installation and maintenance | Instrukcja montażu i konserwacji | Montage- und Wartungsanleitung | Notice de montage et d'entretien
Istruzioni di montaggio e manutenzione | Instrucțiuni de instalare și întreținere | Szerelési és karbantartási utasítás

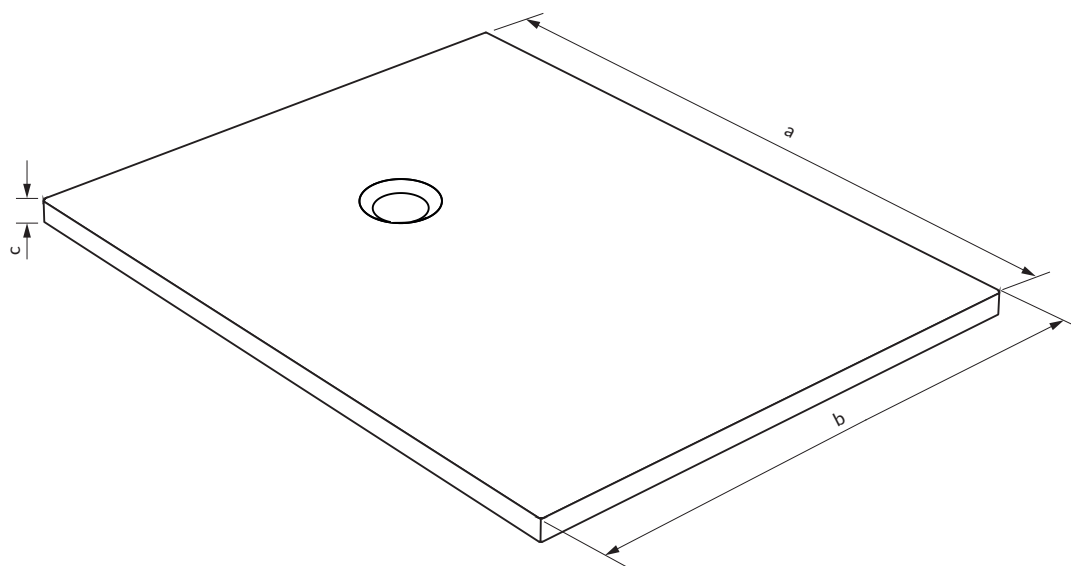

| | a [mm] | b [mm] | c [mm] |
|----------------|--------|--------|--------|
| AQUAPURE80-K | 800 | 800 | 20 |
| AQUAPURE80-100 | 1000 | 800 | 23 |
| AQUAPURE80-120 | 1200 | 800 | 26 |
| AQUAPURE80-140 | 1400 | 800 | 29 |
| AQUAPURE80-160 | 1600 | 800 | 33 |
| AQUAPURE90-K | 900 | 900 | 22 |
| AQUAPURE90-100 | 1000 | 900 | 23 |
| AQUAPURE90-120 | 1200 | 900 | 26 |
| AQUAPURE90-140 | 1400 | 900 | 29 |
| AQUAPURE90-160 | 1600 | 900 | 33 |



Product care
Pielegnacja
Pflege
Soin
Cura
Întreținere
Ápolás

A

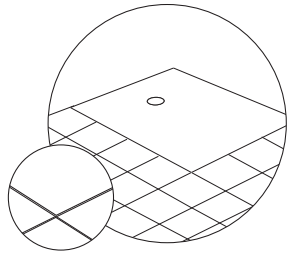

Flush with the floor
Na równi z podłoga
Bündig mit dem Boden
Au niveau du sol
A filo pavimento
La același nivel cu podeaua
Padlószintbe süllyesztve

page 3

B

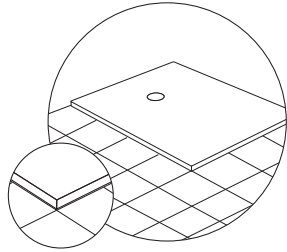

On the floor
Na podłodze
Auf dem Boden
Sur le sol
Sul pavimento
Pe podea
Padlóra helyezve

page 5

C

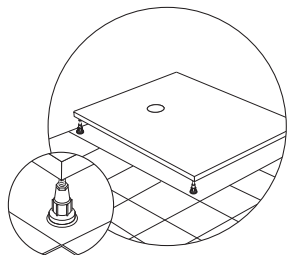

On feet
Na nóżkach
An den Füßen
Sur les pieds
Su piedini
Pe picioare
Lábakon elhelyezve

page 7

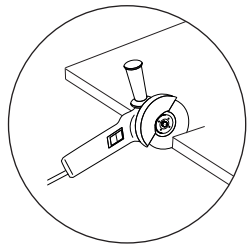

Shower tray cutting instruction
Instrukcja cięcia brodzików
Duschwannen-Schneideanleitung
Manuel de découpe des receveurs de douche
Istruzioni per il taglio del piatto doccia
Instrucțiuni de tăiere a cădiței de duș
Zuhanytálca vágási útmutató

page 12



A

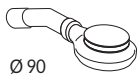

Ø 90



B

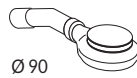

Ø 90

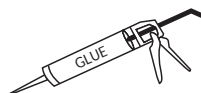

C

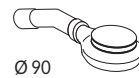

Ø 90

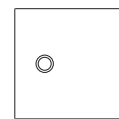

<1000mm

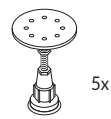

5x

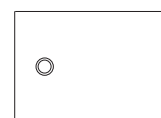

≥1000mm



8x

A

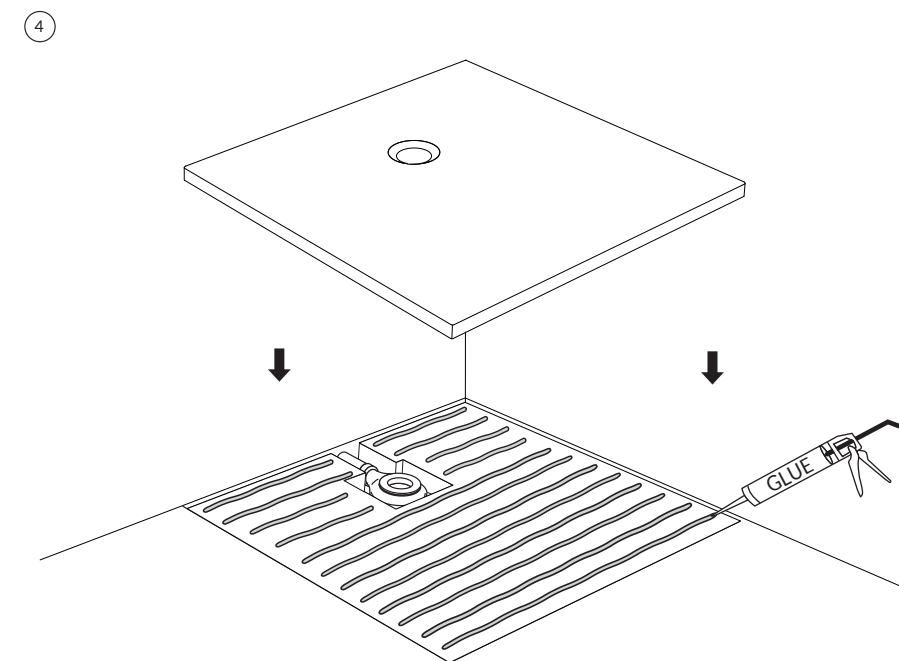
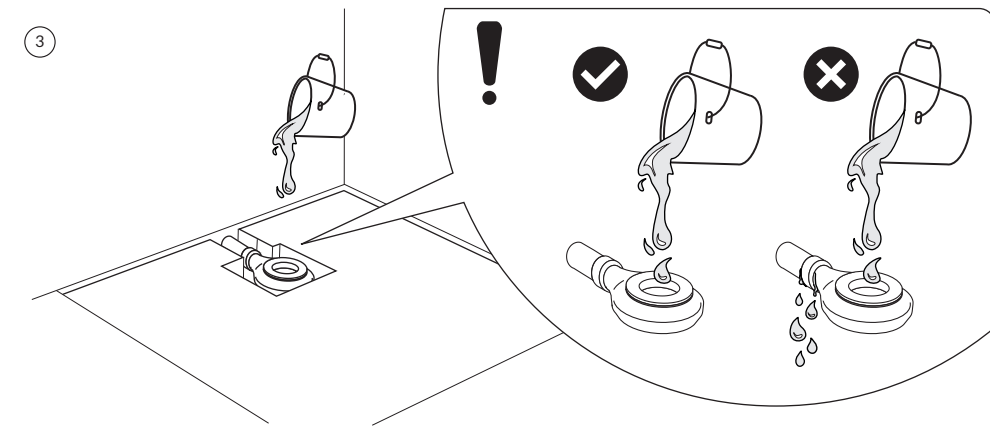
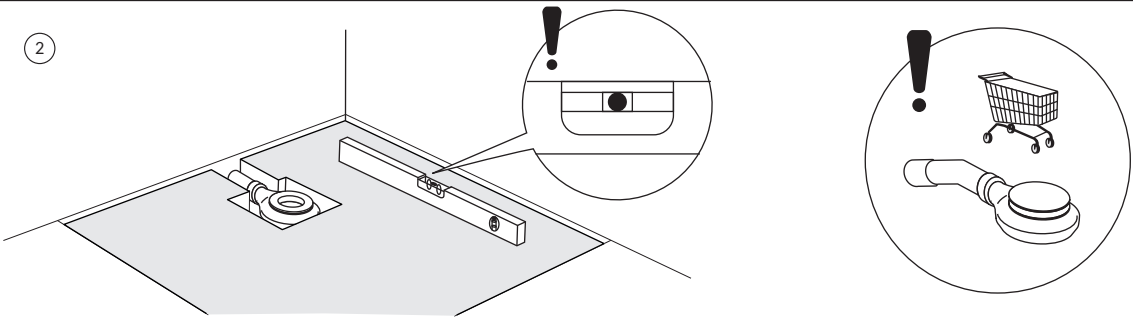
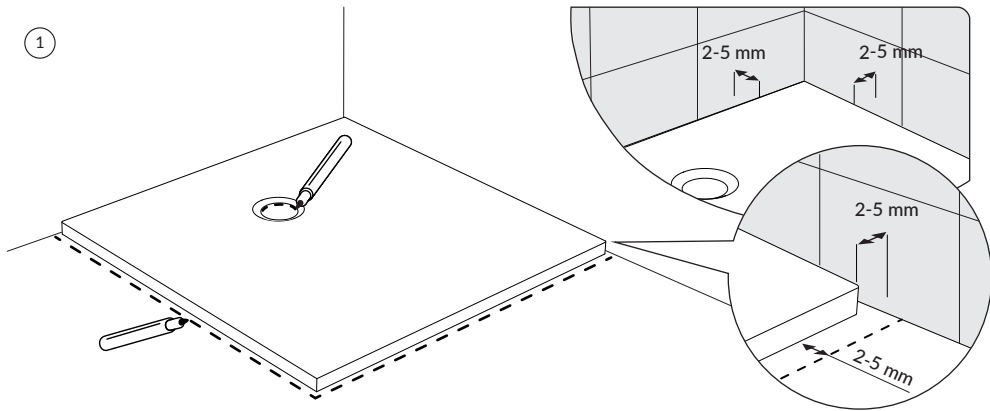

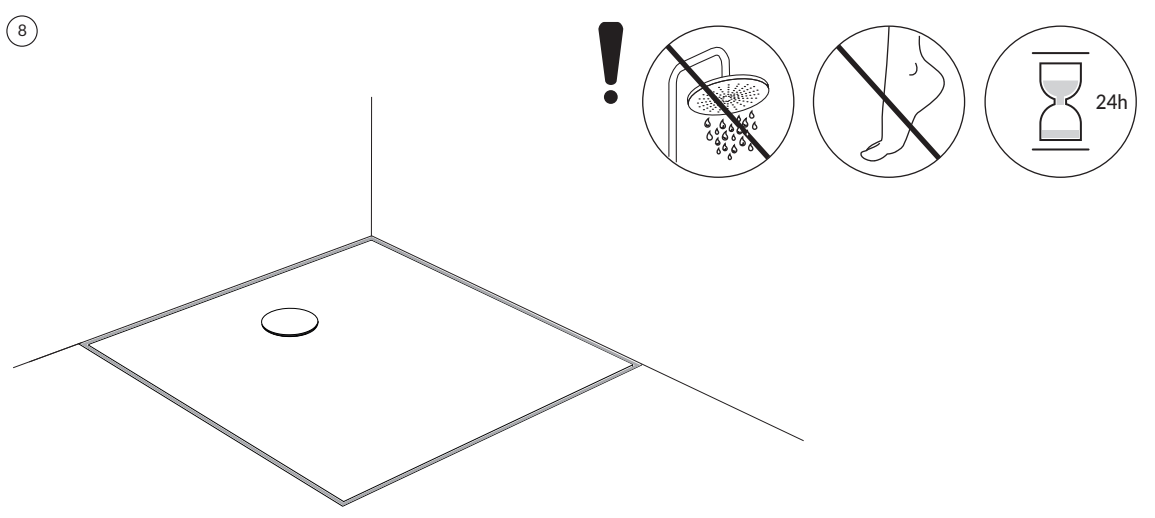
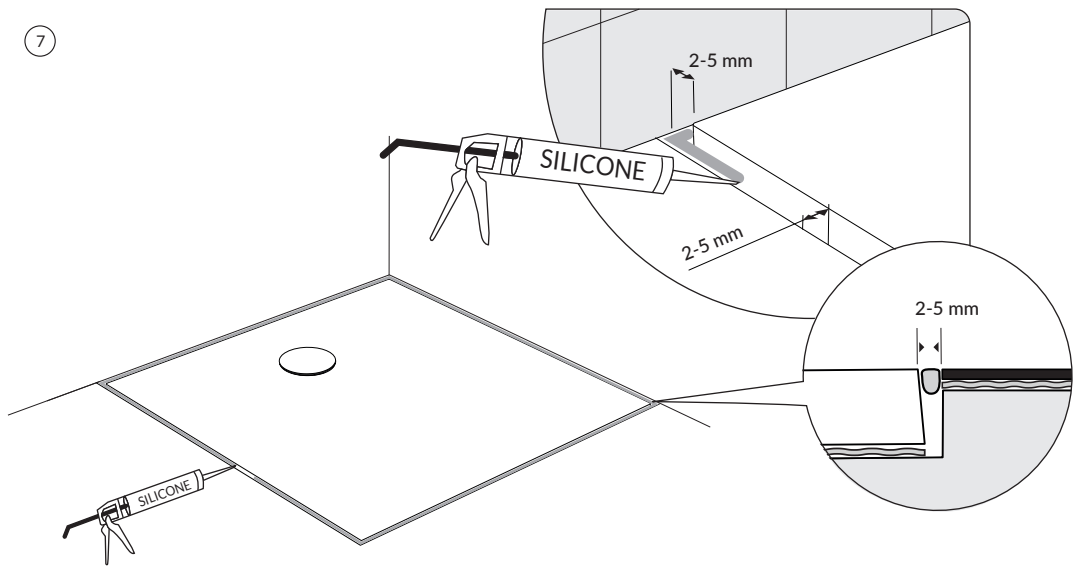
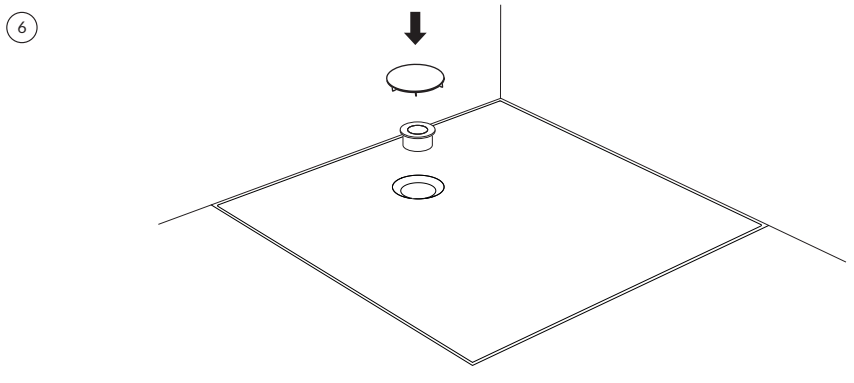
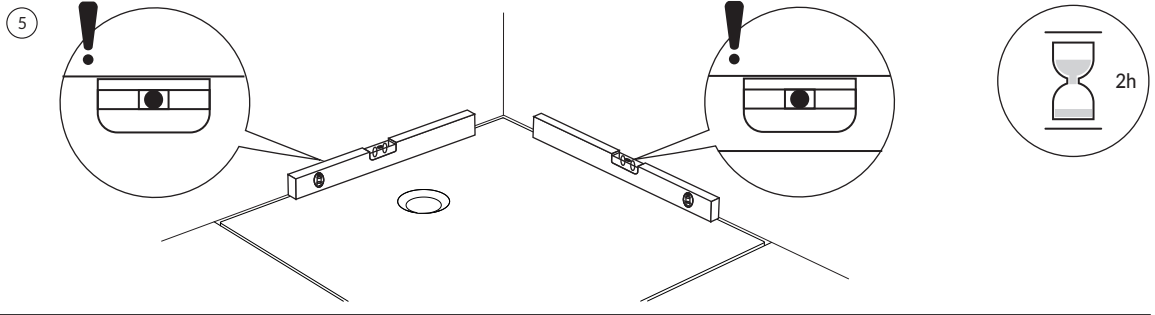

B

①

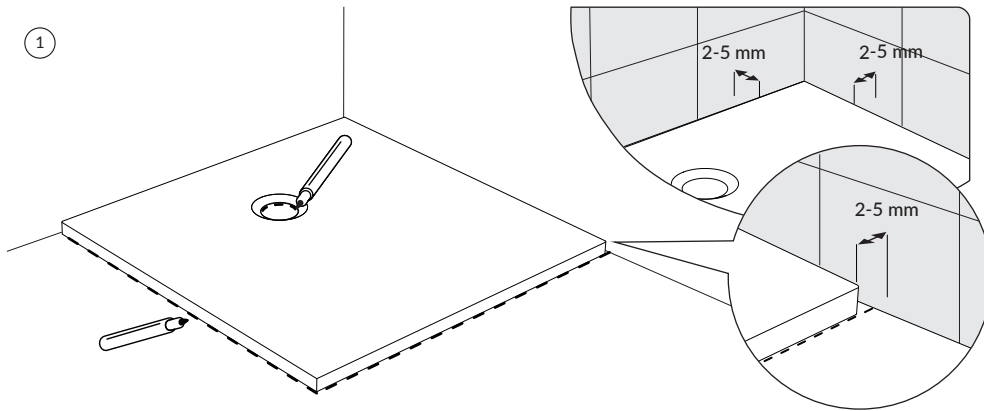

②

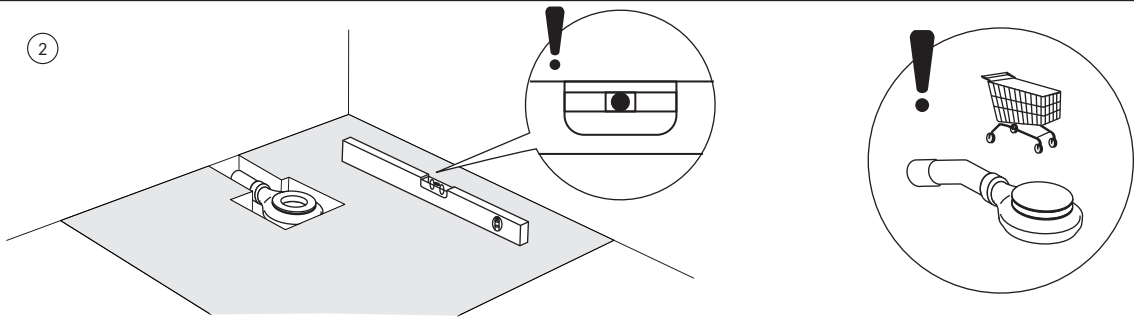

③

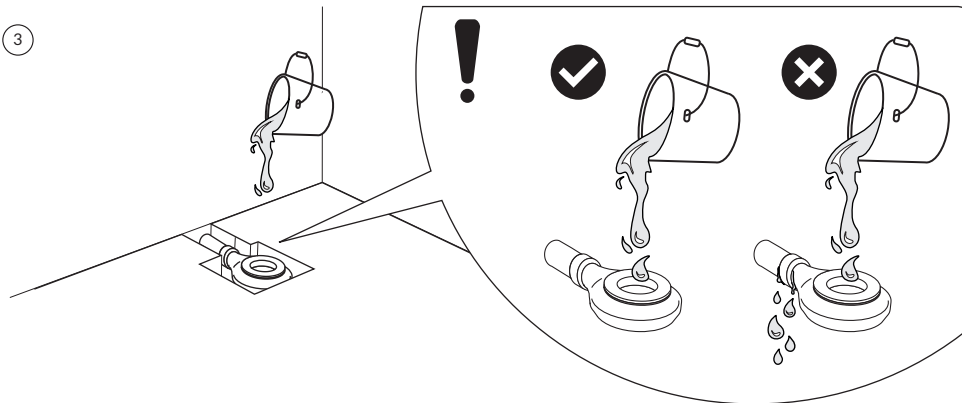

④

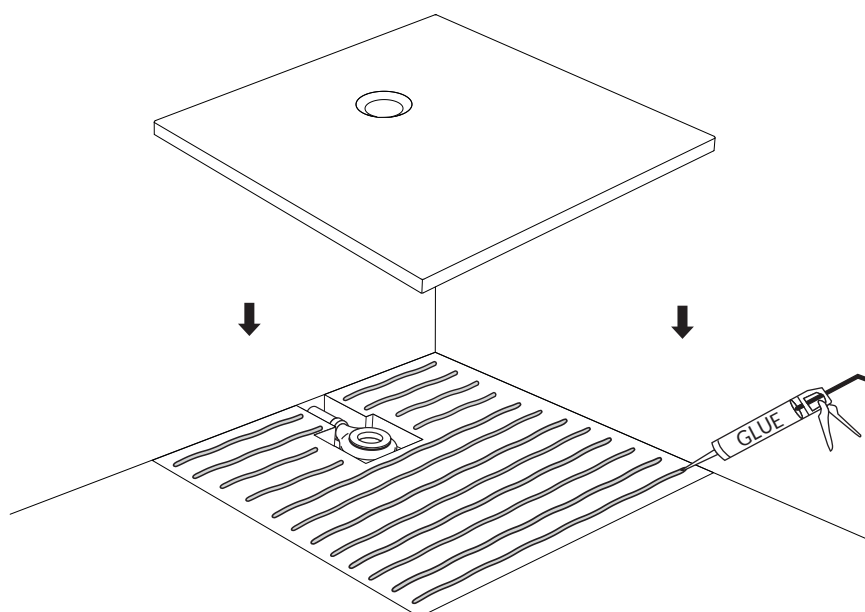

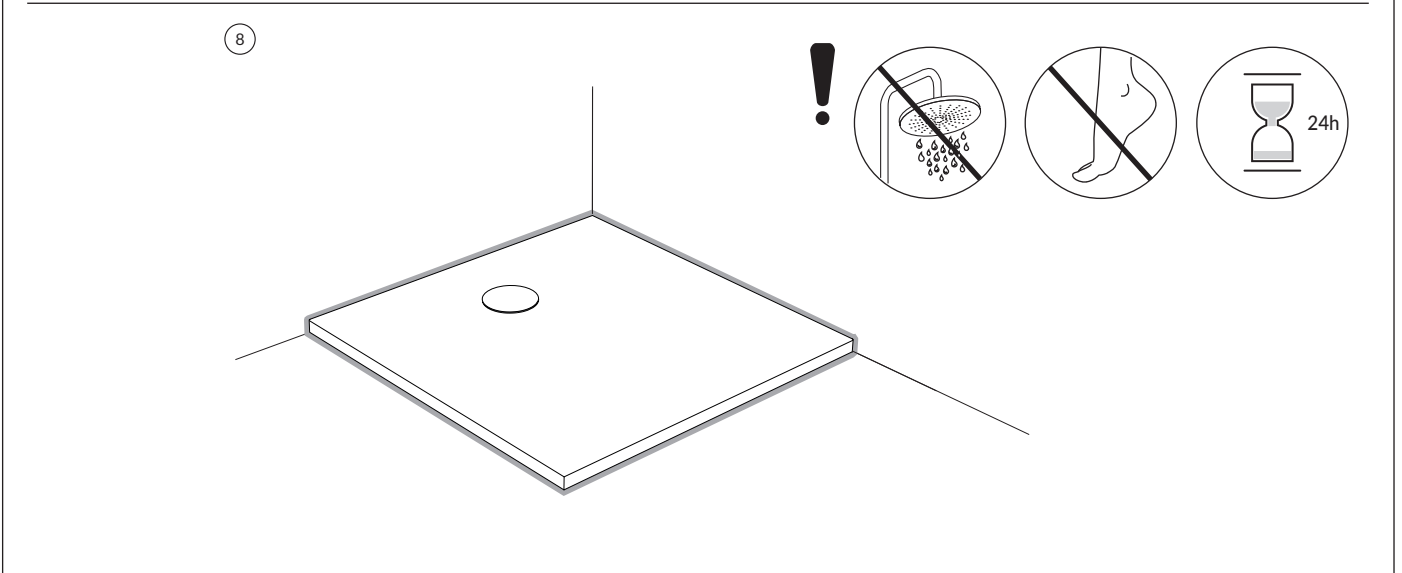
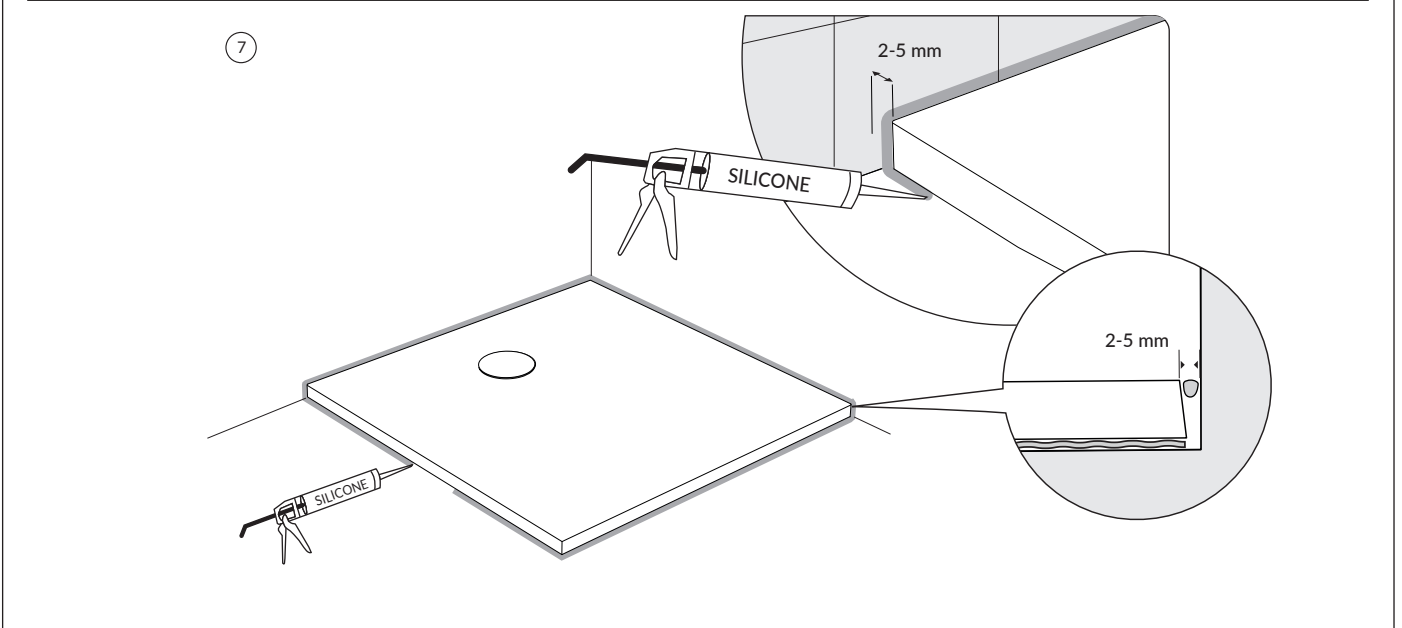
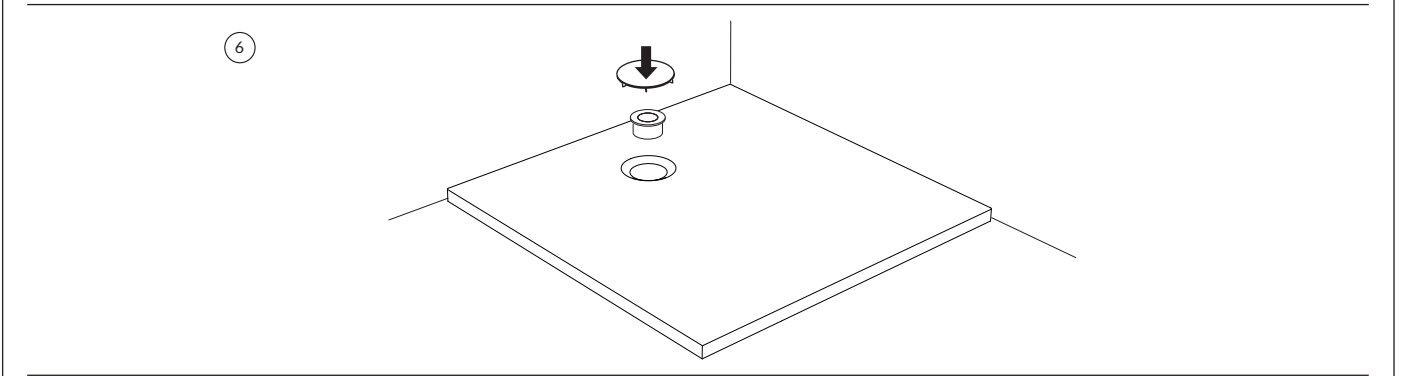
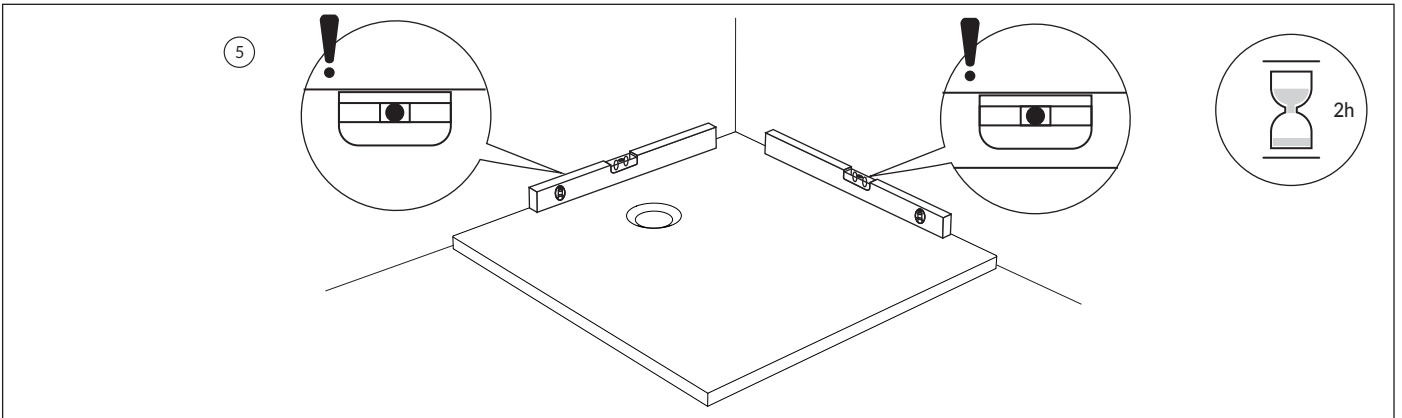

C

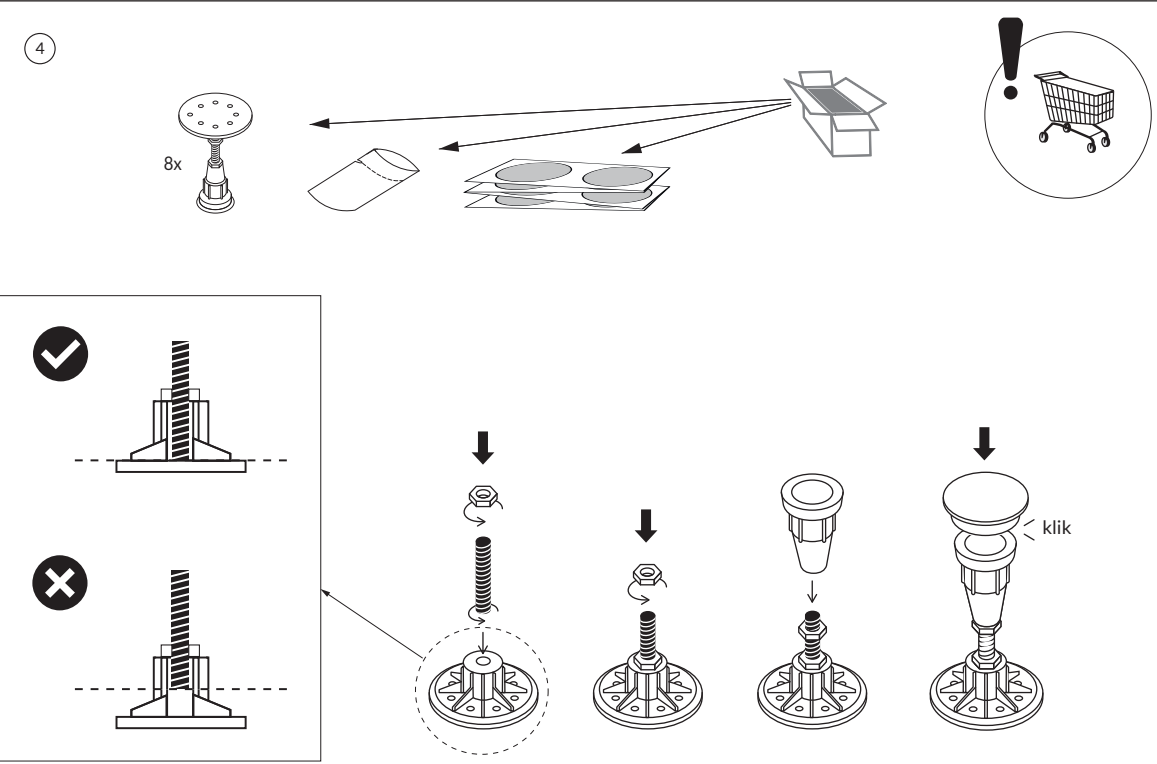
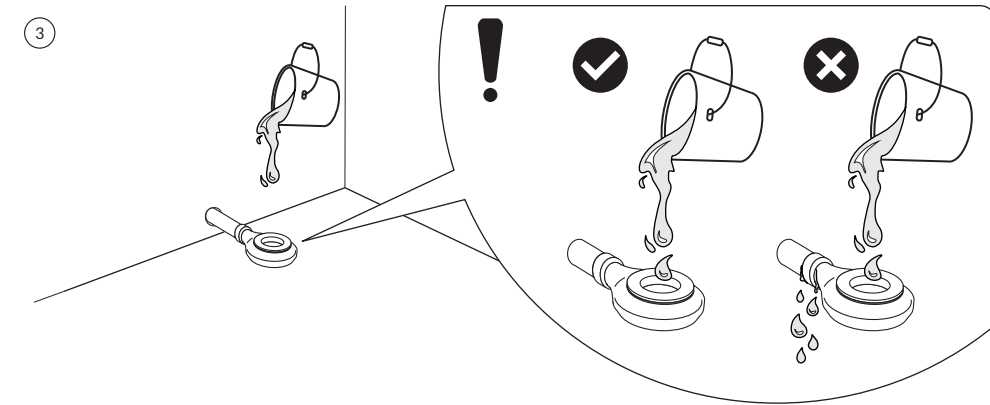
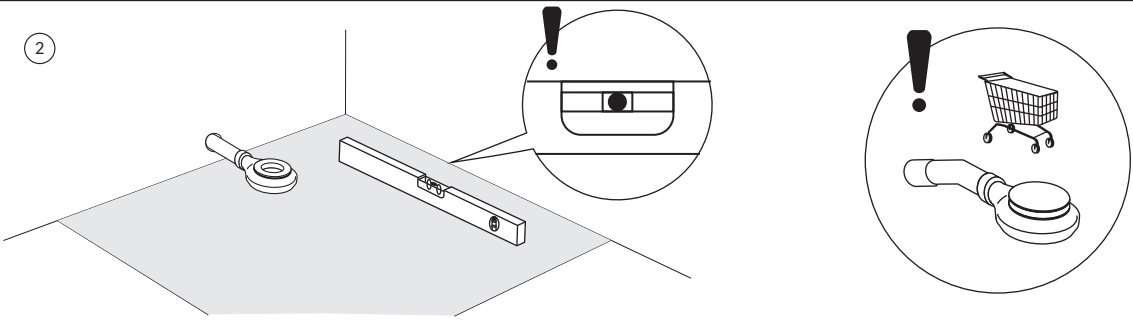
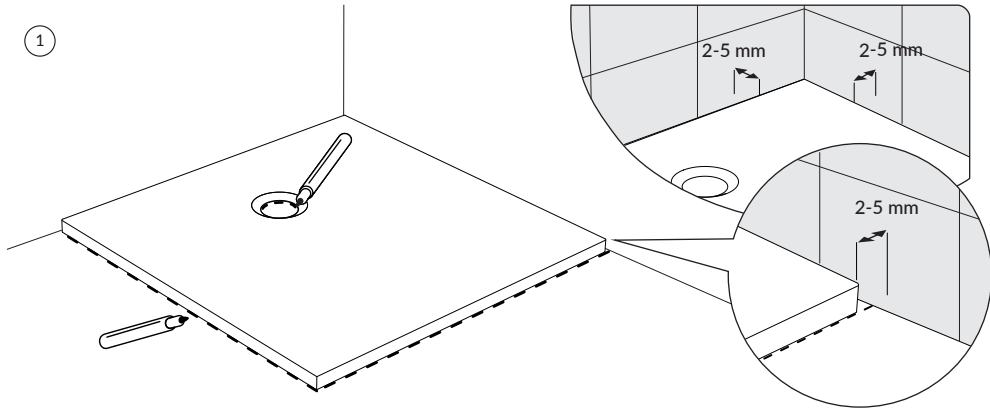

5

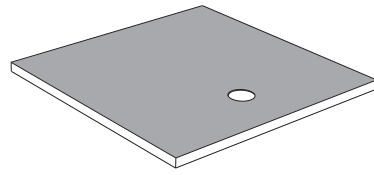
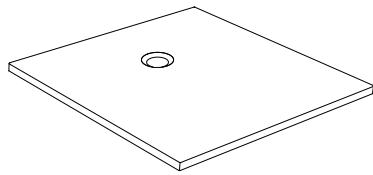

6.1

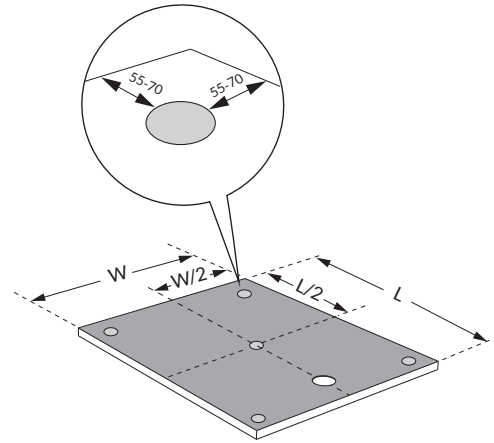
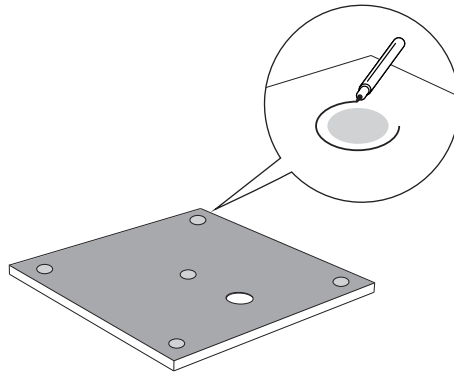
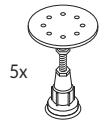
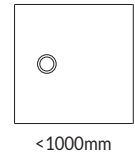
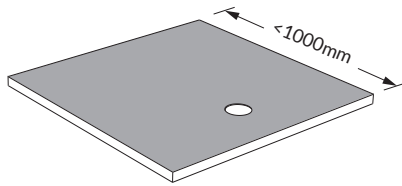

6.2

8x

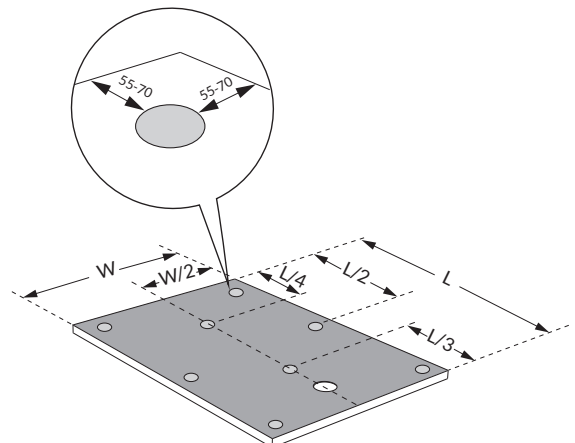
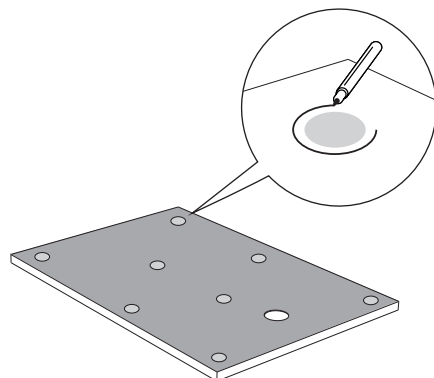
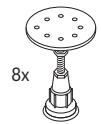
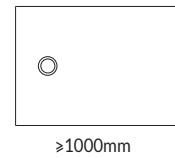
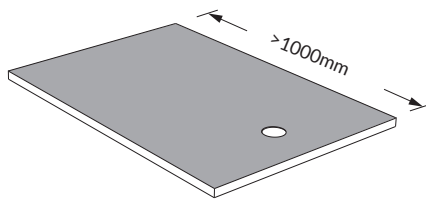

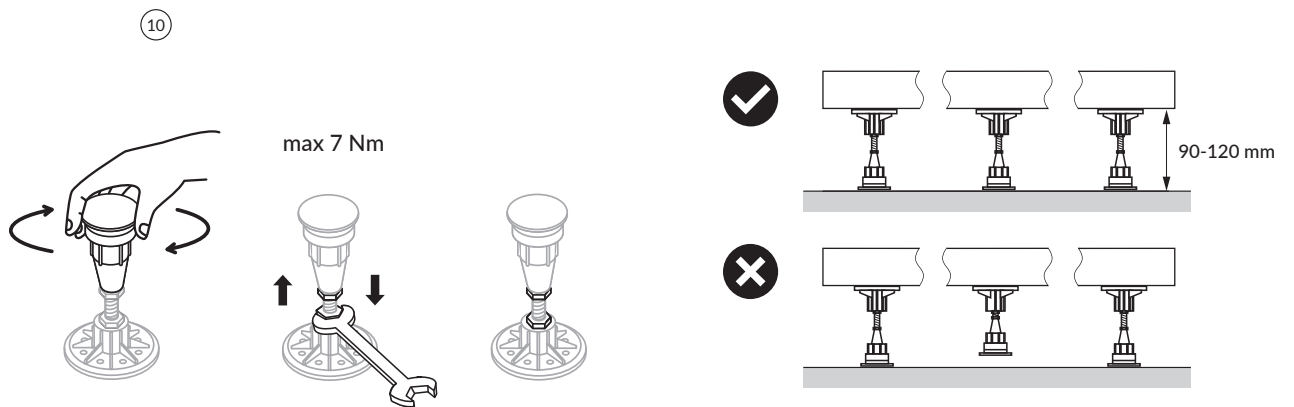
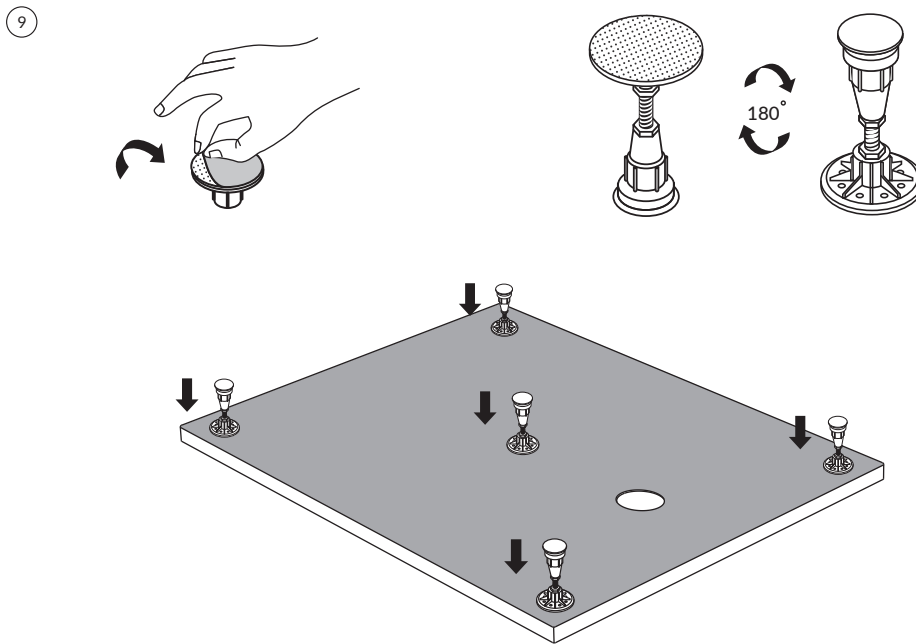
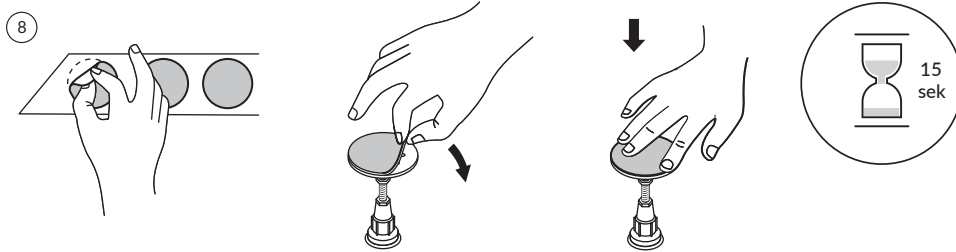
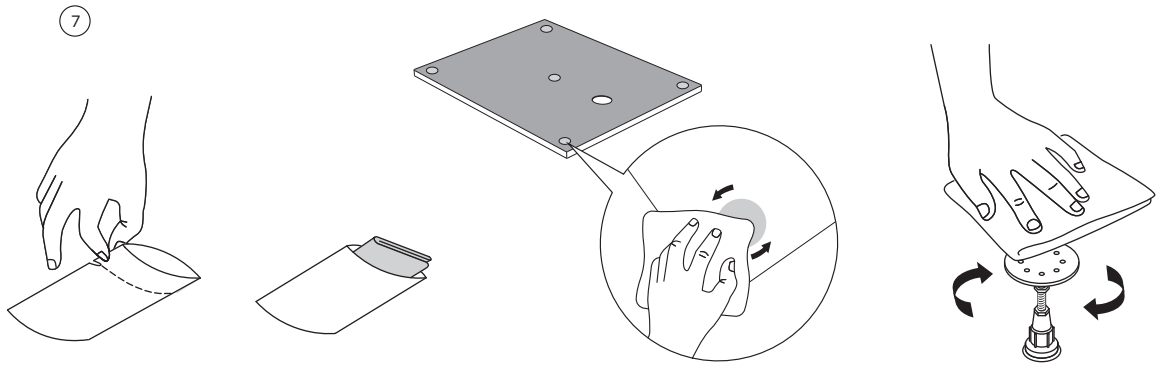

11

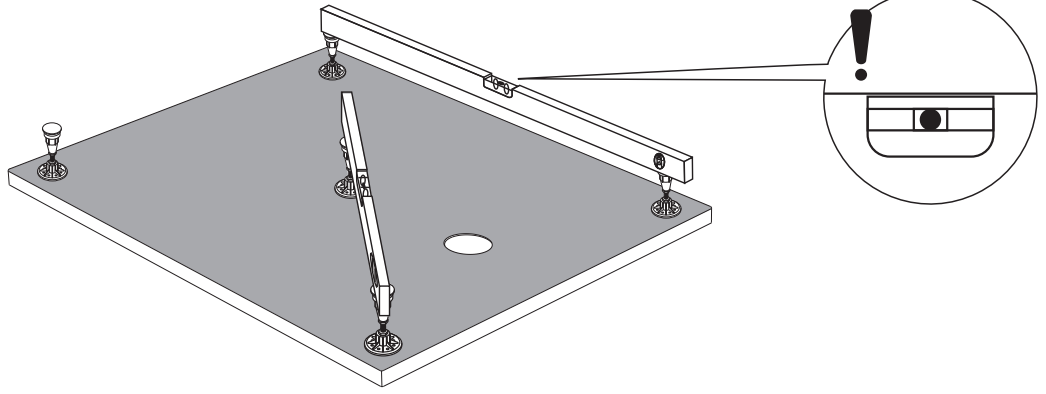

12

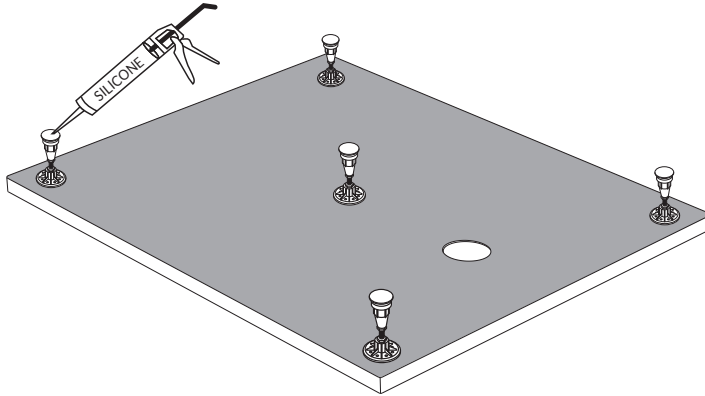

13

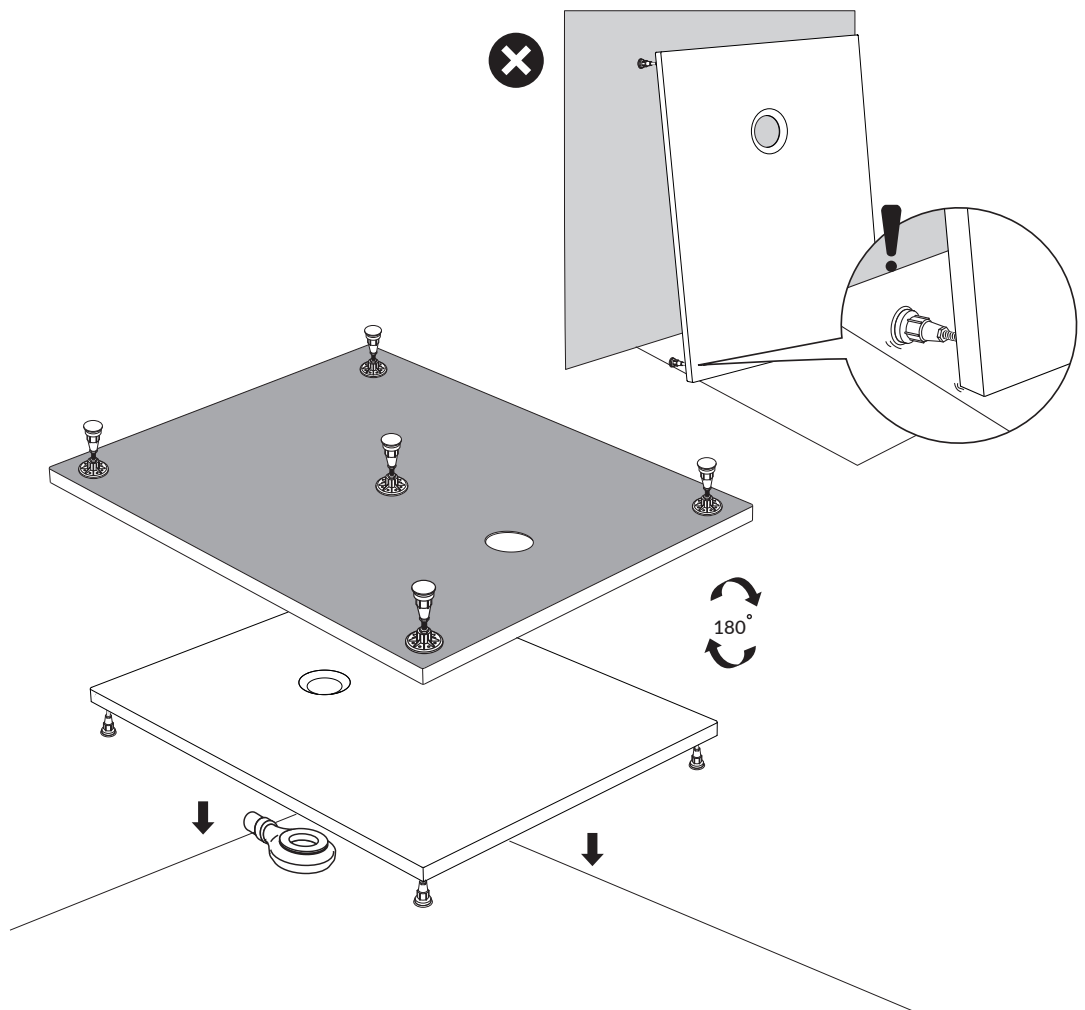

14

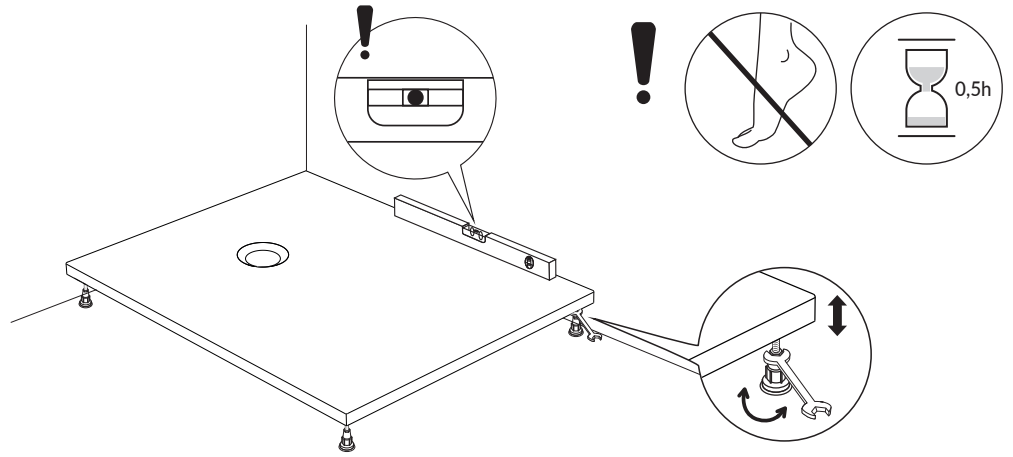

15

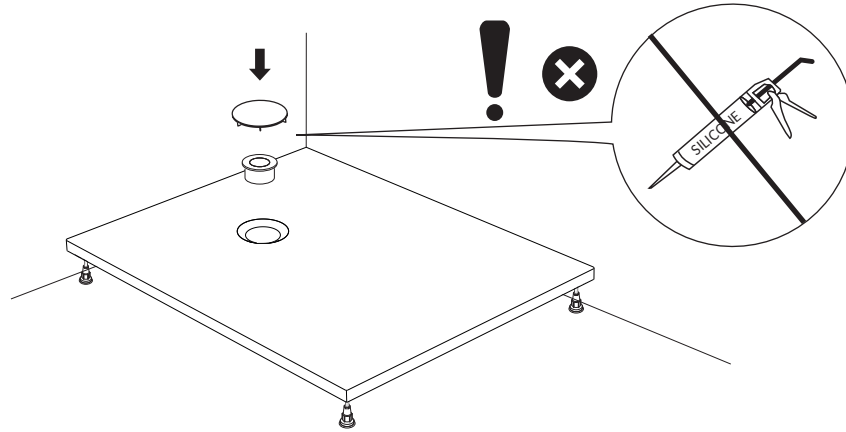

16

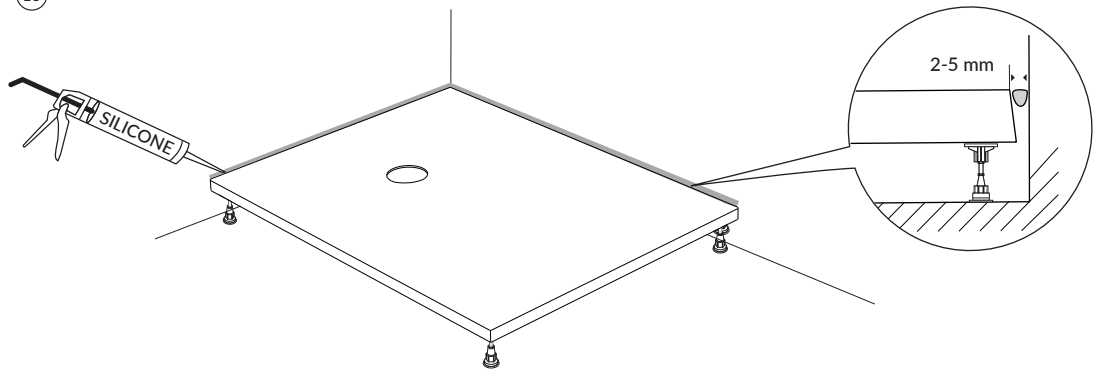

17

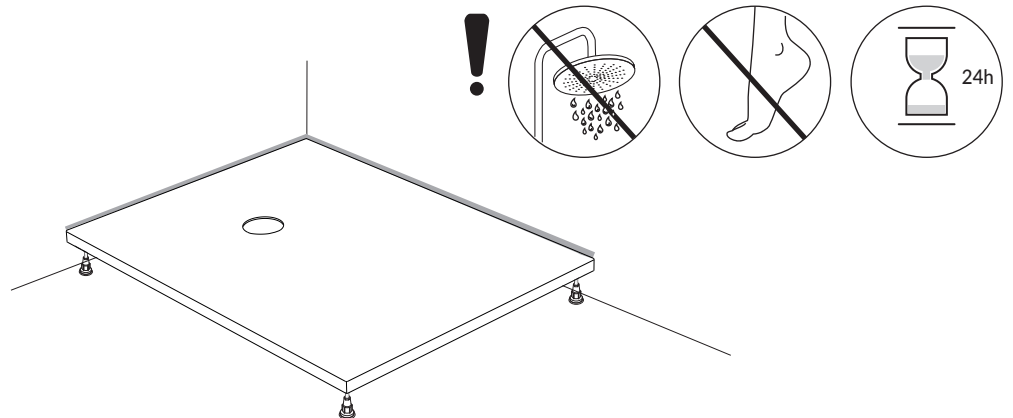

AQUAPURE

Installation and maintenance | Instrukcja montażu i konserwacji | Montage- und Wartungsanleitung | Notice de montage et d'entretien
Istruzioni di montaggio e manutenzione | Instrucțiuni de instalare și întreținere | Szerelési és karbantartási utasítás

EN Please note the following when cutting shower tray:

1. Wear gloves and protective glasses while cutting a shower tray.
2. Cut the shower tray using diamond blades intended for cutting concrete.
3. Do not use a drill in impact mode to drill holes in the shower tray.
4. After cutting, the shower tray must be installed on the floor using assembly adhesive only. Spread the adhesive over the surface of the product in accordance with the installation manual. Do not install the cut shower tray on feet.
5. The manufacturer does not bear any liability for damage caused as a result of cutting the product.

PL Podczas cięcia brodzików należy pamiętać o następujących kwestiach:

1. Cięcie brodzików należy wykonywać w rękawicach i okularach ochronnych.
2. Do cięcia brodzików należy używać ostrzy diamentowych do cięcia betonu.
3. Podczas wiercenia otworów w brodziku nie wolno używać wiertarki ustawionej w trybie udarowym.
4. Brodzik po docinaniu może być montowany wyłącznie na posadzce za pomocą kleju montażowego. Klej należy rozprowadzić pod powierzchnią produktu, zgodnie z instrukcją montażu. Nie wolno instalować docinanego brodzika na nóżkach.
5. Producent nie ponosi odpowiedzialności za wszelkie uszkodzenia powstałe w wyniku cięcia produktu.

DE Hinweise zum Schneiden von Duschwannen:

1. Beim Schneiden von Duschwannen Schutzhandschuhe und Schutzbrille tragen.
2. Zum Schneiden von Duschwannen Diamantscheiben zum Betonschneiden verwenden.
3. Beim Bohren von Löchern in der Duschwanne den Bohrer nicht im Hammermodus verwenden.
4. Die Duschwanne kann nach dem Schneiden nur mit Montagekleber auf dem Boden montiert werden. Der Kleber ist gemäß der Montageanleitung auf der Oberfläche des Produkts zu verteilen. Eine zugeschnittene Duschwanne darf nicht auf Standfüßen installiert werden.
5. Der Hersteller haftet nicht für Schäden, die durch das Schneiden des Produkts entstehen.

FR Les points suivants doivent être pris en compte lors de la découpe des receveurs de douche :

1. La découpe des receveurs de douche doit être effectuée avec des gants et des lunettes de sécurité.
2. Les lames en diamant pour couper le béton doivent être utilisées pour couper les receveurs de douche.
3. Lorsque vous percez des trous dans le receveur de douche, n'utilisez pas de perceuse à percussion.
4. Après la découpe, le receveur de douche ne peut être monté au sol qu'avec de la colle de montage. La colle doit être étalée sur la surface du produit, conformément aux notices de montage. Ne pas installer le receveur de douche découpé sur des pieds.
5. Le fabricant n'est pas responsable des dommages causés par la découpe du produit.

IT Durante il taglio dei piatti doccia è necessario tenere presente quanto segue:

1. Il taglio dei piatti doccia deve essere effettuato indossando guanti e occhiali protettivi.
2. Per tagliare i piatti doccia, utilizzare lame diamantate per il taglio del calcestruzzo.
3. Quando si praticano i fori nel piatto doccia, non utilizzare un trapano impostato in modalità percussione.
4. Dopo il taglio, il piatto doccia può essere installato esclusivamente sul pavimento utilizzando colla di montaggio. La colla deve essere stesa sotto la superficie del prodotto secondo le istruzioni di montaggio. Non è consentito installare un piatto doccia tagliato su piedini.
5. Il produttore non risponde per eventuali danni causati dal taglio del prodotto.

RO Următoarele aspecte trebuie avute în vedere la tăierea cădițelor de duș:

1. Tăierea cădițelor de duș trebuie efectuată cu mănuși și ochelari de protecție.
2. Folosiți discuri diamantate pentru tăierea betonului pentru a tăia cădițele de duș.
3. Atunci când efectuați găuri în cădița de duș, nu utilizați un burghiu setat în modul impact.
4. După tăiere, cădița de duș poate fi instalată numai pe podea, cu adeziv de montaj. Adezivul trebuie să fie distribuit sub suprafața produsului în conformitate cu instrucțiunile de instalare. Nu instalați cădița de duș tăiată pe picioare.
5. Producătorul nu este responsabil pentru nicio deteriorare cauzată de tăierea produsului.

HU A zuhanytálcák vágása során az alábbi szempontokat kell figyelembe venni:

1. A zuhanytálcák vágását védőkesztyűben és védőszemüvegben kell végezni.
2. A vágáshoz beton vágására alkalmas gyémánt vágótárcsát kell használni.
3. A zuhanytálcán történő furatkészítés során tilos az ütvefúró (ütvefúrési módra állított fúrógép) használata.
4. A méretre vágott zuhanytálca kizárólag a padlóra ragasztva szerelhető be, szerelési ragasztó segítségével. A ragasztót a termék teljes alsó felülete alatt, a szerelési útmutatónak megfelelően kell elosztani. A méretre vágott zuhanytálca nem szerelhető fel lábakra.
5. A gyártó nem vállal felelősséget a termék vágásából eredő károkért.



A

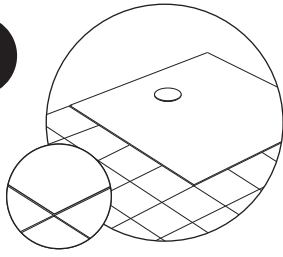

Flush with the floor
Na równi z podłogą
Bündig mit dem Boden
Au niveau du sol
A filo pavimento
La același nivel cu podeaua
Padlószintbe süllyesztve

B

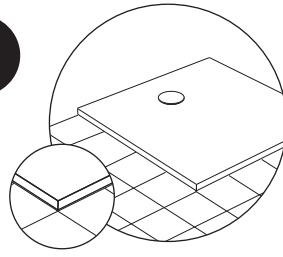

On the floor
Na podłodze
Auf dem Boden
Sur le sol
Sul pavimento
Pe podea
Padlóra helyezve



C

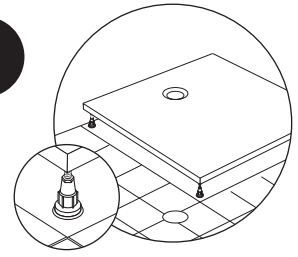

On feet
Na nóżkach
An den Füßen
Sur les pieds
Su piedini
Pe picioare
Lábakon elhelyezve

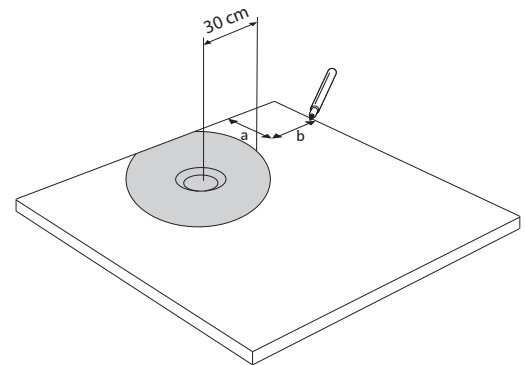
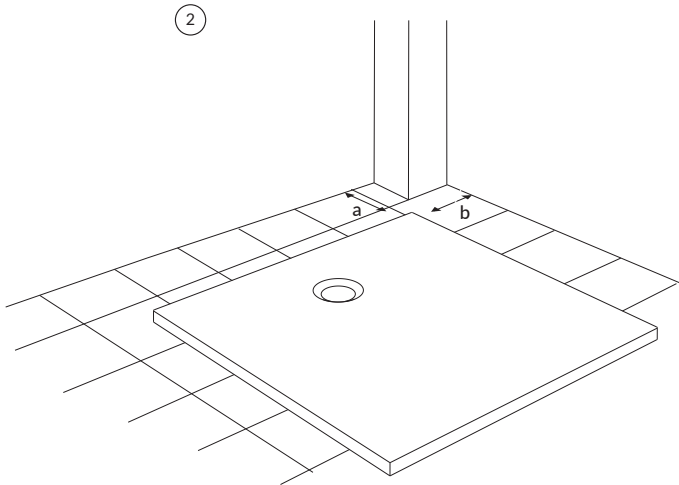
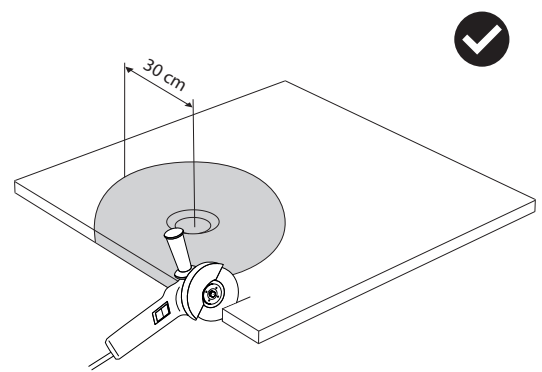
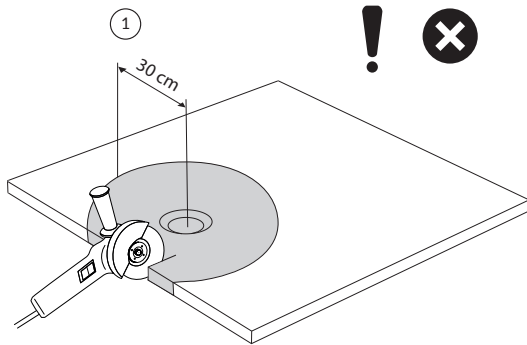

3

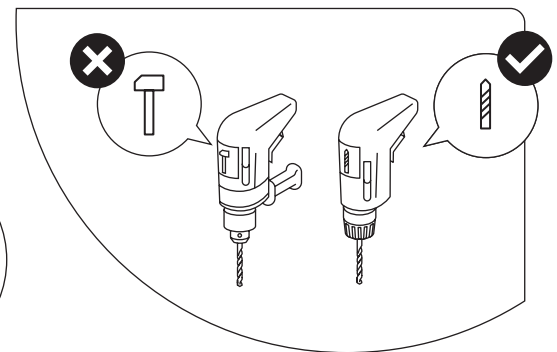
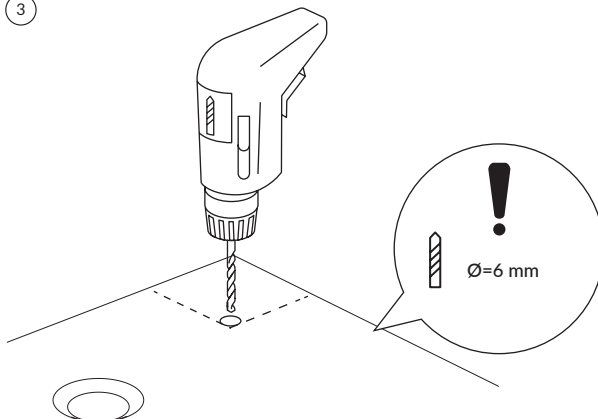

4

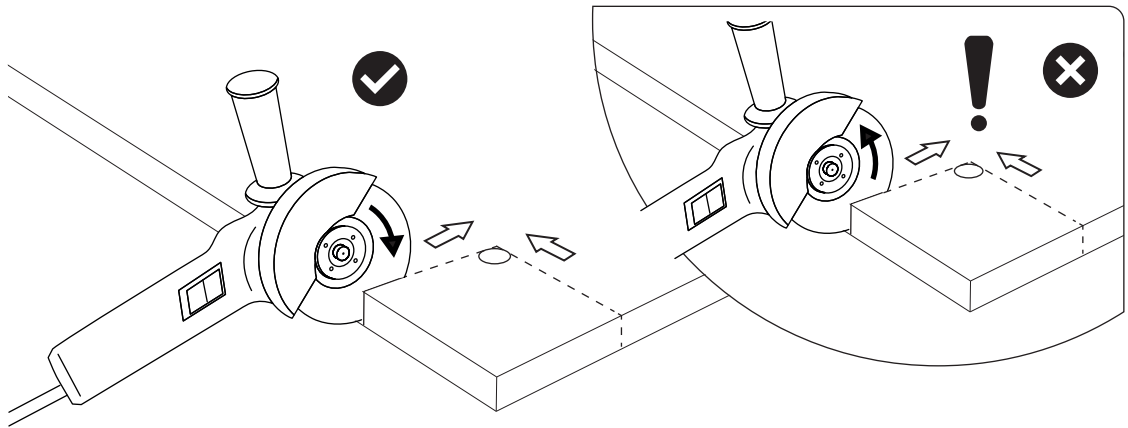

5

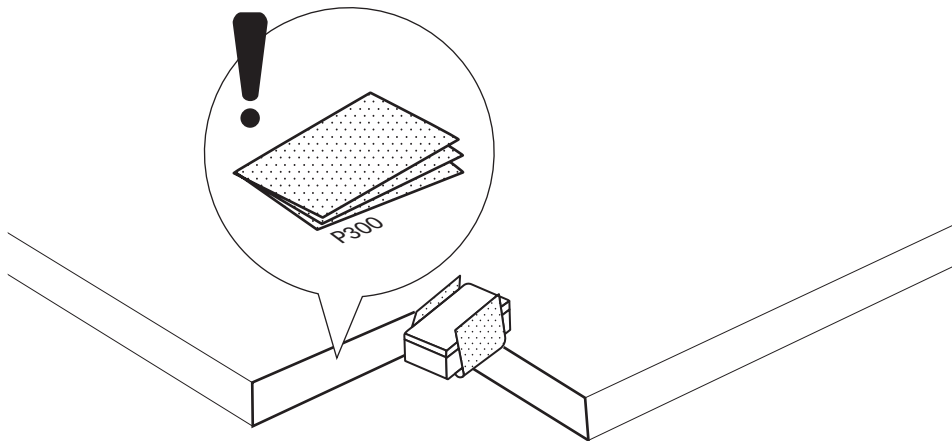

6

A

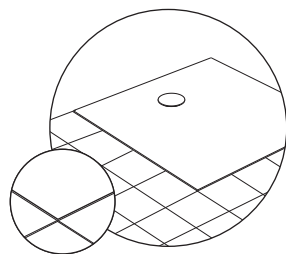

page 3

Flush with the floor
 Na równi z podłogą
 Bündig mit dem Boden
 Au niveau du sol
 A filo pavimento
 La același nivel cu podeaua
 Padlószintbe süllyesztve

B

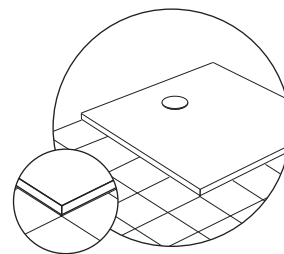

page 5

On the floor
 Na podłodze
 Auf dem Boden
 Sur le sol
 Sul pavimento
 Pe podea
 Padlóra helyezve